

# S Series SIZE 100 .100 CENTERS

### BeCu PLUNGERS

		<b>A</b>
		<b>B</b>
		<b>D</b>
		<b>F</b>
		<b>G</b>
		<b>H</b>
		<b>HK</b>
		<b>HL</b>
		<b>HSC</b>
		<b>J</b>
		<b>JS</b>
		<b>K</b>
		<b>LM</b>
		<b>S</b>
		<b>T</b>
		<b>TX</b>
		<b>V</b>
		<b>W</b>

### STEEL PLUNGERS

		<b>B</b>
		<b>M</b>
		<b>NT</b>
		<b>R</b>
		<b>S</b>
		<b>SN</b>

### PROBE SPECIFICATIONS

Minimum Centers: .100 (2,54)  
 Current Rating: 3 amps continuous  
 Spring Force: 3.5, 5.5, 6.7, 8.0, 10.0 or 17.0 oz. @ .170 (4,32) travel  
 Contact Resistance: <8 mΩ  
 Working Travel: .170 (4,32)

Rated Force oz (gms)	Preload oz (gms)	Material
3.5 (99)	1.5 (43)	SS
5.5 (156)	2.4 (68)	MW
6.7 (190)	2.8 (80)	SS
8.0 (227)	3.3 (94)	MW
10.0 (283)	3.7 (105)	MW
17.0 (483)	6.8 (193)	MW

### RECEPTACLE SPECIFICATIONS

Connections:  
 R(X)100-CR: Crimp  
 R(X)100-SC: Solder Cup  
 R(X)100-WW: Wire Wrap, .025 (0,64) square post, .429 (10,90) length or .694 (17,63) length  
 R(X)100-RP: Round Post .025 (0,64) diameter .375 (9,53) length

**Recommended Wire:** 22-26 gage  
**Drill Size:** #50  
**Mounting Hole Size:** .068/.070 (1,73/1,78)

### STEEL PLUNGERS (CONTINUED)

		<b>SP</b>
		<b>SPB</b>
		<b>SW</b>
		<b>SWS</b>
		<b>U</b>

### STEEL PLUNGERS (CONTINUED)

		<b>UR</b>
		<b>UST</b>
		<b>VLT</b>
		<b>WO</b>
		<b>Y</b>

### S-100 PROBE AND RECEPTACLE

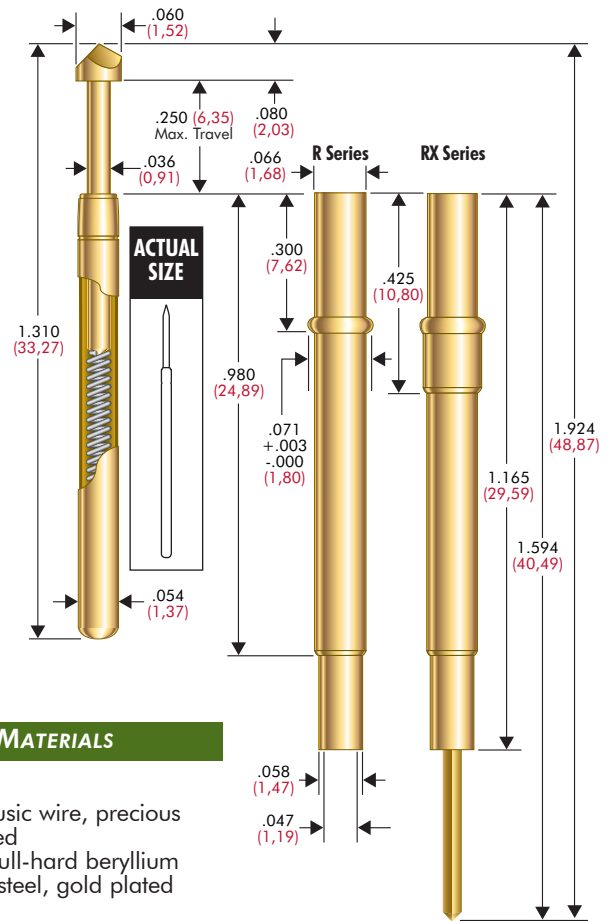

### MATERIALS

Barrel: G2  
 Spring: Music wire, precious metal plated  
 Plunger: Full-hard beryllium copper or steel, gold plated over nickel  
 Receptacle: Nickel / silver, gold plated post

### HOW TO ORDER: SPRING CONTACT PROBE

<b>S</b>	<b>100</b>	<b>T</b>	<b>5.5</b>	<b>G</b>	<b>S</b>
SERIES	SIZE	TIP STYLE	SPRING FORCE	PLATING OPTION	STEEL PLUNGER OPTION

**SERIES:**  
 S: Standard Performance (No Bifurcated Beam)  
**CRIMPING PLIERS:** CPR100  
**INSERTION TOOL:** RTR100

**SPRING FORCE:**  
 3.5 oz. @ .170 (4,32) travel  
 5.5 oz. @ .170 (4,32) travel  
 6.7 oz. @ .170 (4,32) travel  
 8.0 oz. @ .170 (4,32) travel  
 10.0 oz. @ .170 (4,32) travel  
 17.0 oz. @ .170 (4,32) travel

### RECEPTACLE

<b>R</b>	<b>100</b>	<b>WW</b>	<b>429</b>
SERIES	SIZE	TERMINATION	POST LENGTH

**SERIES:**  
 R: High Performance  
 RX: Improved Pointing Accuracy, High Performance  
 RS: Standard Performance  
 RSX: Improved Pointing Accuracy, Standard Performance

**TERMINATION:**  
 CR: Crimp  
 SC: Solder Cup  
 WW: Wire Wrap  
 RP: Round Post

**POST LENGTH:**  
 WW: 429 or 694  
 RP: 375

Previously ordered as R-25-WW-429

View updates of this information at <http://www.idinet.com>

Specifications subject to change without notice. Dimensions in inches (millimeters)